

SICO Tri-Height Stage

The Sico Tri-Height Stage is a system that features three variable height adjustments, making for much more versatile staging. Set-up at a single level for meeting room stages, fashion runways, or head table settings. Set-up tiered configurations for seating or choral risers.

Easy to operate:

- Requires minimal effort to set-up, keeping staffing requirements and labor costs to a minimum.

Easy to set-up and take-down:

- Each section rolls in on 5-inch (13cm) swivel rubber casters and is quickly and easily set into place. The wheels lower automatically and engage to the floor as the unit is folded and rolled into storage.

Less Units to be Handled:

- 6' x 8' (183cm x 244cm) stages make for the perfect head table riser. Allows 30" (76cm) for tables, 18" (46cm) for chairs, plus 24" (61cm) for serving space. 4' x 8' (122cm x 244cm) require twice as many units.

1



- Low see-through profile allows for easy movement of stage units.



- A spring assist pop-up feature assists in the deck reversal without dismantling a stage set-up.



- Rigid one piece unitized steel frame supports the decks. The decks nest firmly within the frames.



- More staging options! Reversible decks feature a combination of carpet and hard surface, or hard surface on both sides.

- Velcro on all sides of stage makes for quick and easy adjustable drape attachment. Drapes are adjustable, allowing for full deck-to-floor coverage at all heights.

- Tri-Height stages are designed to meet or exceed industry standards.

Larger Decks Reduce Cost:

- 6' x 8' (183cm x 244cm) stages require less units for staging configurations compared to 4' x 8' stages (122cm x 244cm).

Security:

- Over-center locking mechanism keeps legs locked into place during transport.

Accessories:

- Adjustable step units, ADA ramps, guard rails, guard rail covers, chair/table stops and drapes.

Service:

- Sico offers free space analysis drawings, which will provide accurate layouts for your venue with the appropriate number of stages and stage accessories.

Specifications:

- See specifications on page 10.

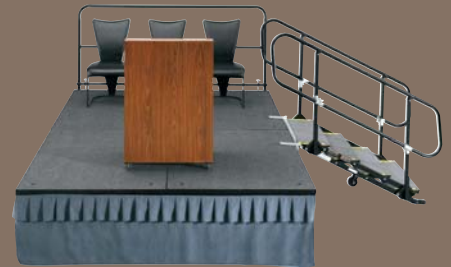

● Simply remove four bolts (with conventional allen wrench or power drill) to easily reverse deck surface.

● Two stages in one: carpet or hard surface.

● Changing heights is simple with the Sico built-in lock and pin mechanism. Just rotate the yellow handle and adjust to the desired height. Adjusts in 6" (15 cm) increments, adhering to ADA (Americans with Disabilities Act) requirements.

● Overlapping of decks in the riser set-up eliminates the possibility of chair legs sliding through. No additional chairstop required!

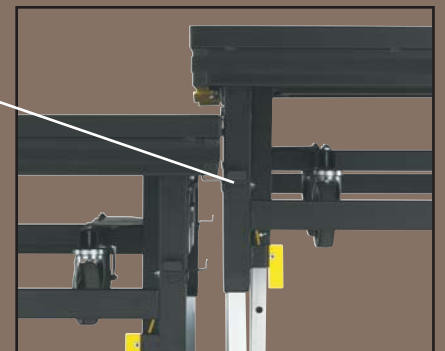

● The stage sections lock together with built-in unit-to-unit connectors when units are at the same or varying heights. No cords, Velcro, straps, or tape are necessary to hold stages in place.